

# The Nostrum Network on Chip

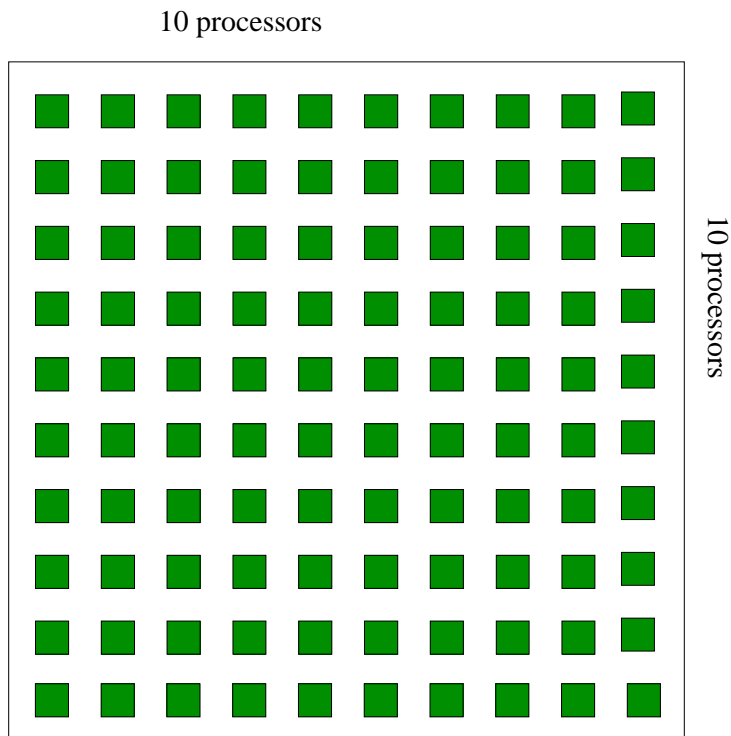

Axel Jantsch

Royal Institute of Technology, Stockholm

November 2003

# Overview

Introduction

Topology and Structure

Protocol Stack

The Network Layer and the Switch

Data Protection



# The Challenge

10 processors

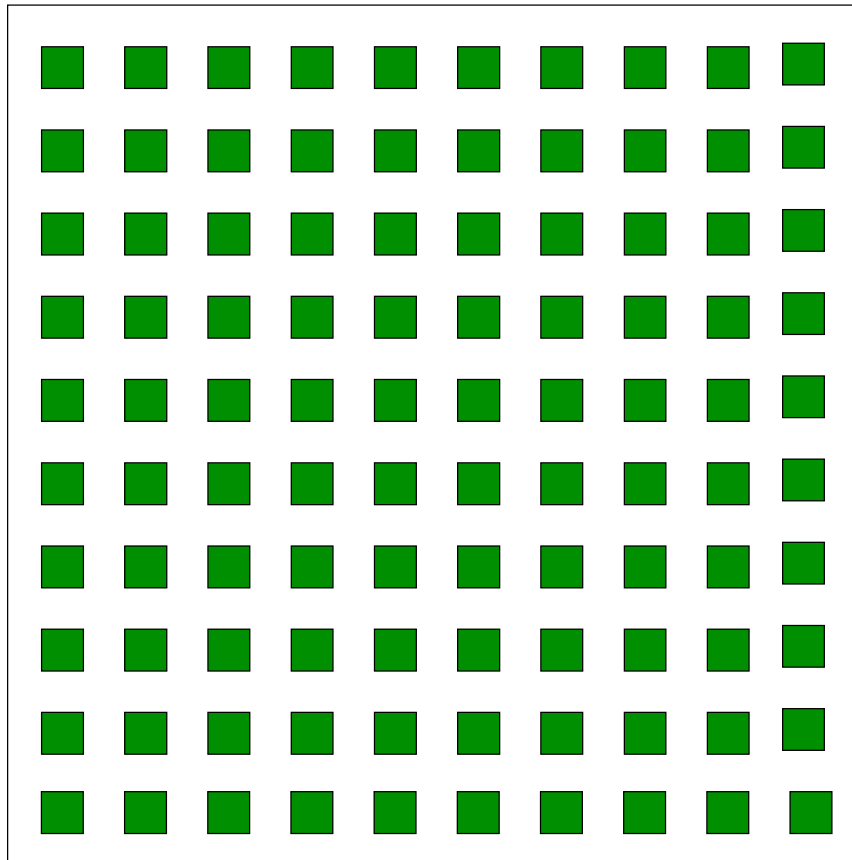

# Gates	# Processors	Year
6 M	4	2000
24 M	16	2003
96 M	64	2006
384 M	256	2009



# Functions, Architecture, and Physics

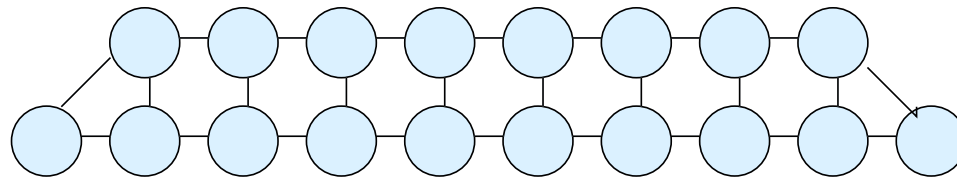

Concurrent  
processes

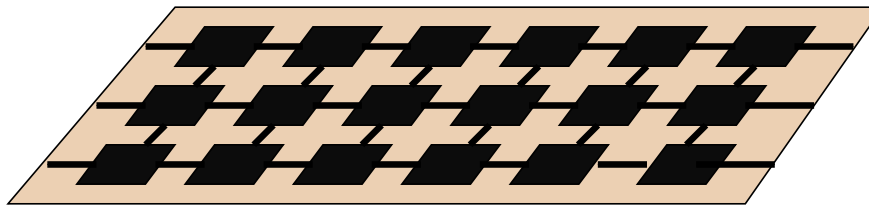

Large number  
of resources

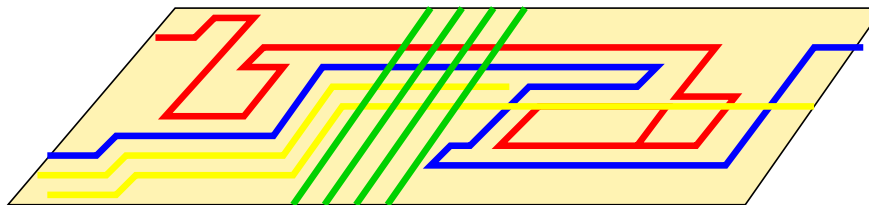

Physical  
issues

# Motivation

- A systematic approach to on-chip communication is a necessity;
- General platform for a variety of applications;
- Flexibility by means of selection of resources and communication services;
- Reuse of design and verification of communication services, architecture and implementation;
- Reuse of resources and features (system functionality + resource implementation);
- Better controllable physical properties;



## Challenge Areas: Physical Issues

- Deep submicron effects, noise, signal integrity
- Interconnect
- Power consumption, power delivery
- Clock distribution
- Memory integration (50-80% of the chip)





## Challenge Areas: Methodology

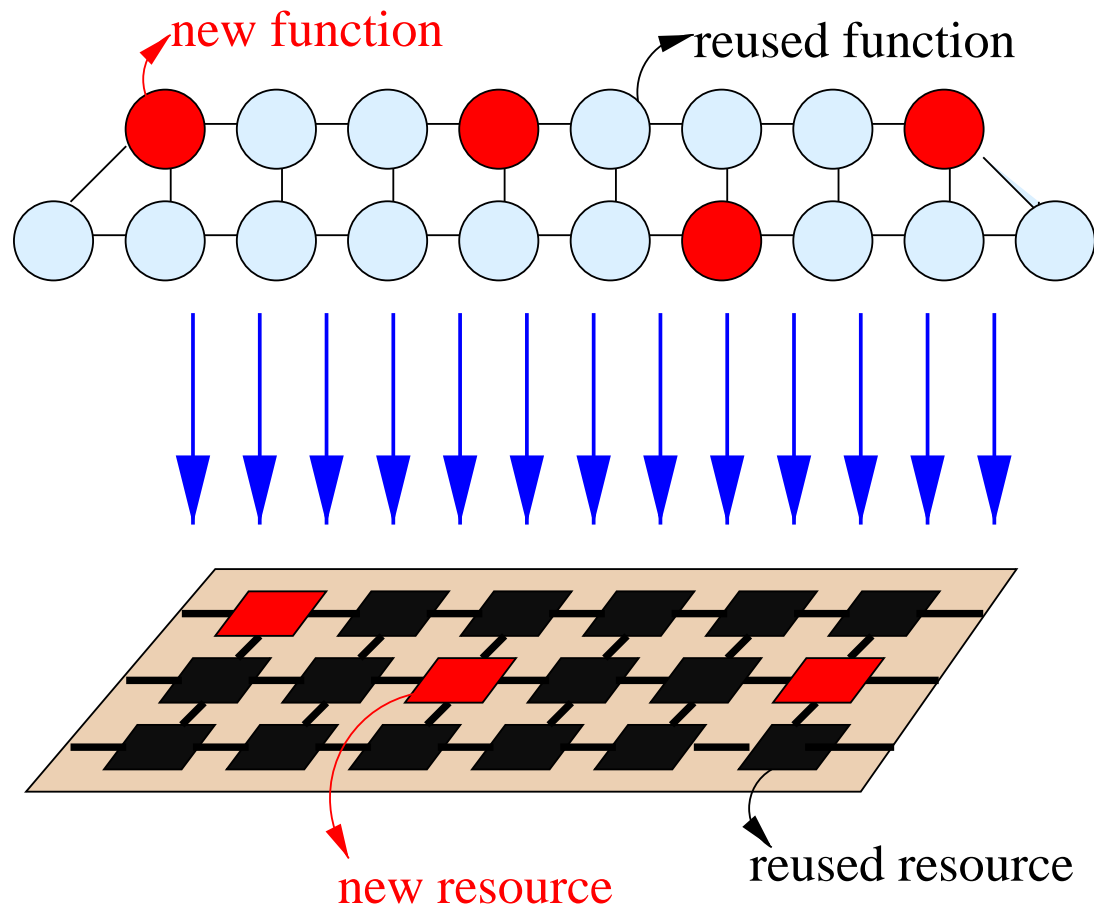

- Specification techniques of concurrent activities
- Performance analysis
- Reuse and Integration of both functions and components

## Challenge Areas: Run Time Services

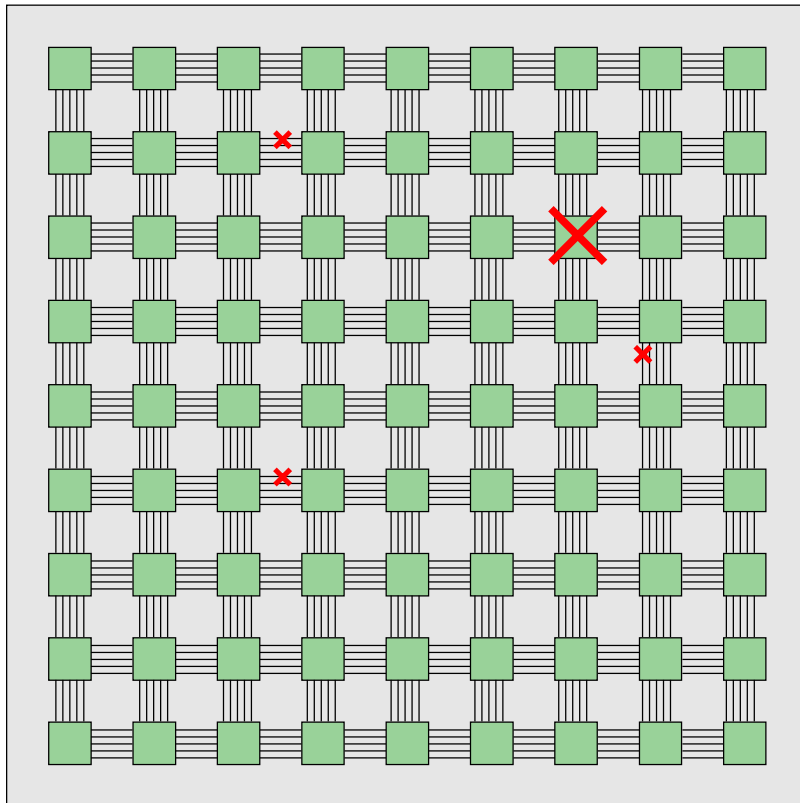

- Monitoring
- Fault-tolerance,
- Diagnostics
- Fault recovery
- Dynamic resource management

## Challenge Areas: Configurability

A sensible trade-off between efficiency and generality is critical.

- Configurability of communication resources from the data link to the application layer
- Configurability of resources (processors, DSPs, FPGAs, etc.)
- When and who?
  - ★ Design-time configuration: Platform  $\Rightarrow$  Product
  - ★ Static product configuration: Once for a product
  - ★ Dynamic reconfiguration: Programming of the product



# Overview

Introduction

**Topology and Structure**

Protocol Stack

The Network Layer and the Switch

Data Protection



# Nostrum Topology: Mesh

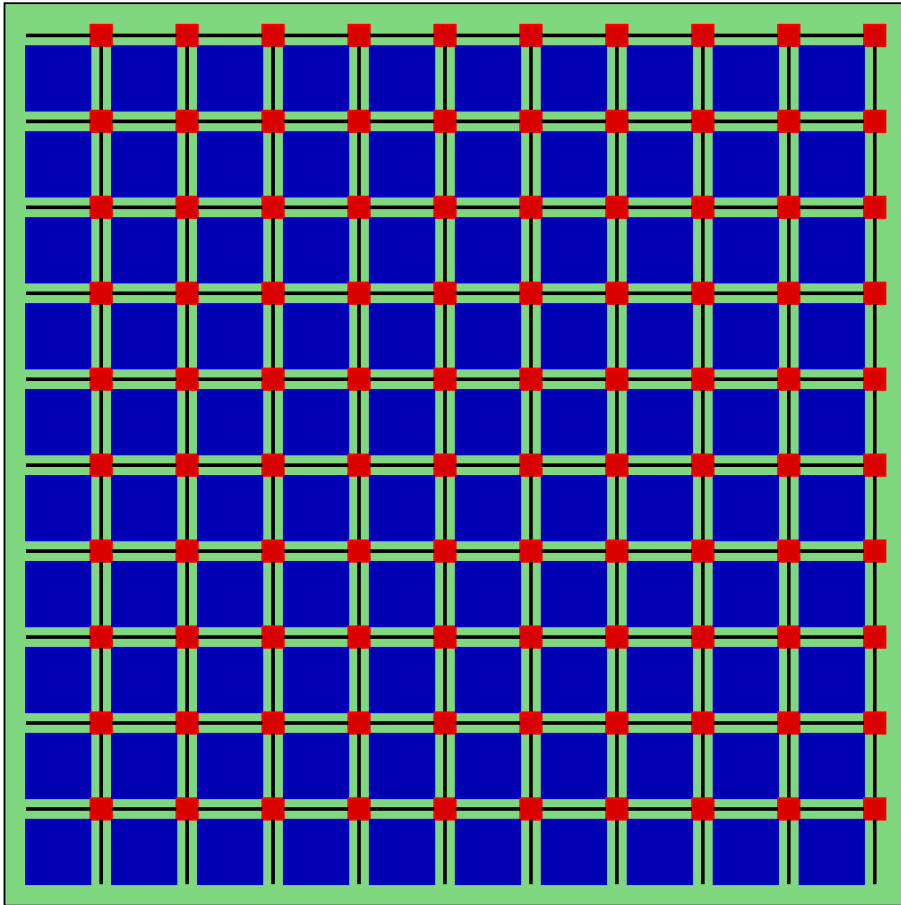

## Characteristics:

- Resource-to-switch ratio: 1
- A switch is connected to 4 switches and 1 resource
- A resource is connected to 1 switch
- Max number of hops grows with  $2n$

## Motivation:

- Regularity of layout; predictable electrical properties
- Expected locality of traffic

# The Node in a Mesh

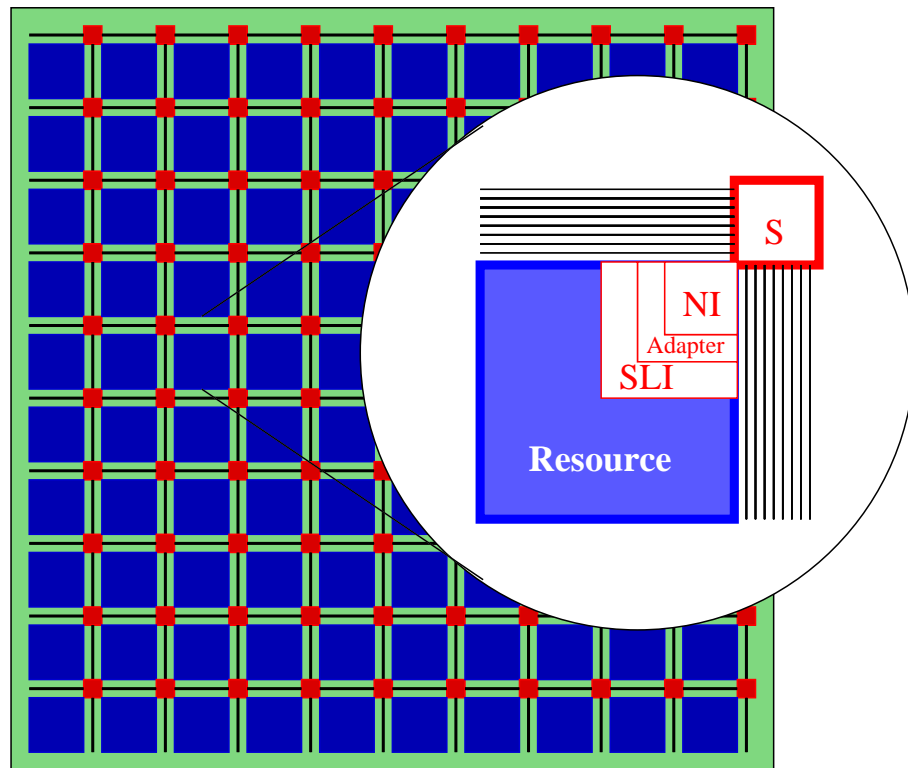

## NI: Network Interface:

- Compulsory
- HW
- Implements the network layer protocol

**Adapter:** Resource specific interface circuit;

## SLI: Session Layer Interface:

- Optional
- Hardware and/or software
- Implements the session layer protocol

## Scenario: Thin Switch

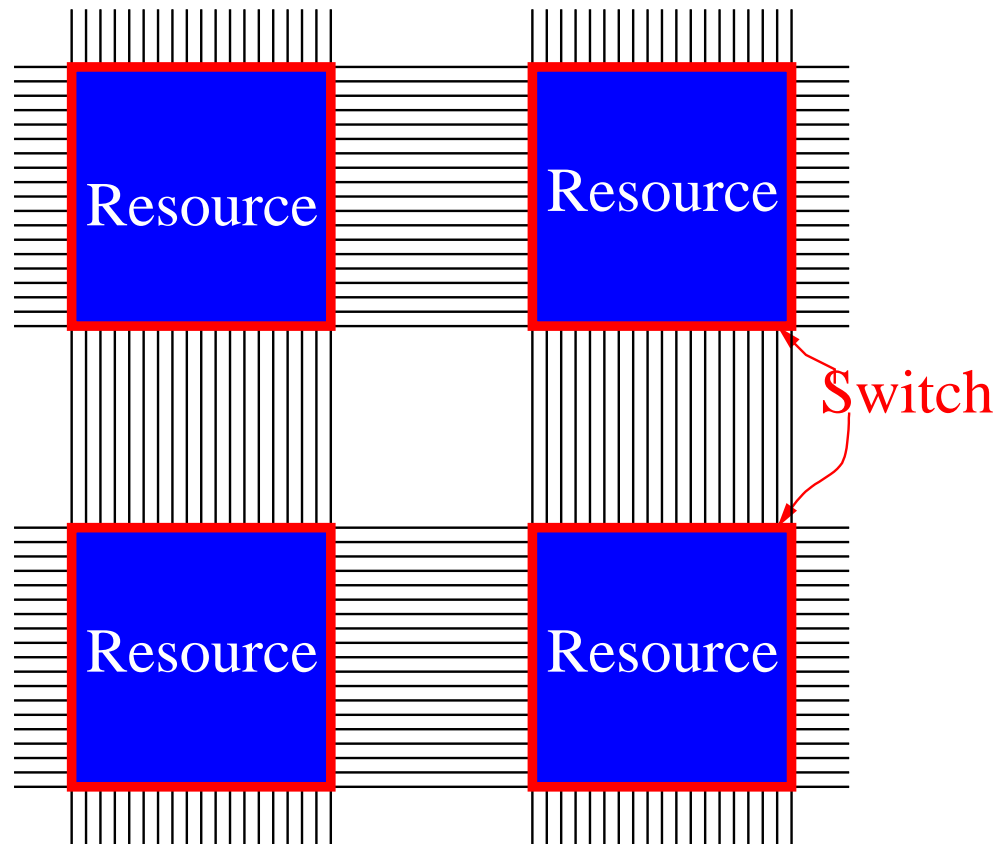

- 65 nm CMOS
- $22 \times 22$  mm Chip size
- $2 \times 2$  mm resource size
- 300 nm minimum wire pitch
- Wires are routed across resources
- 6600 wires between two resources on each metal layer
- Network area overhead: 5% – 25%

## Scenario: Square Switch

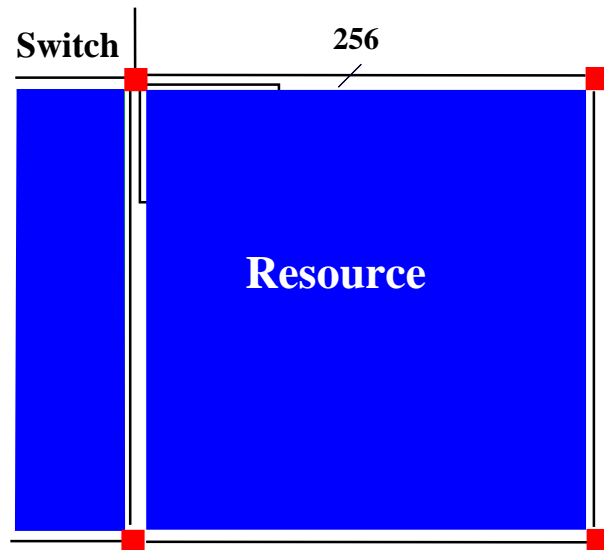

- 65nm CMOS
- $22 \times 22mm^2$  Chip size
- $2 \times 2mm^2$  resource size
- 300nm minimum wire pitch
- Wires are routed in  $200\mu m$  channels between resources
- $100\mu m \times 100\mu m$  switch
- 660 wires between two resources on each metal layer
- switch-to-switch connection: 256 wires
- switch-to-resource connection: 256 wires
- Network area overhead:  $\sim 10\%$

# Overview

Introduction

Topology and Structure

**Protocol Stack**

The Network Layer and the Switch

Data Protection





# Physical Layer

Parameters:

- Physical distance
- Number of lines
- Activity control
- Buffers and pipelining

Nostrum status:

- Channel dimension:  
 $2mm \times 100\mu m$
- 128 data lines in each direction on 4 metal layers
- No pipelining
- On/off control for power saving

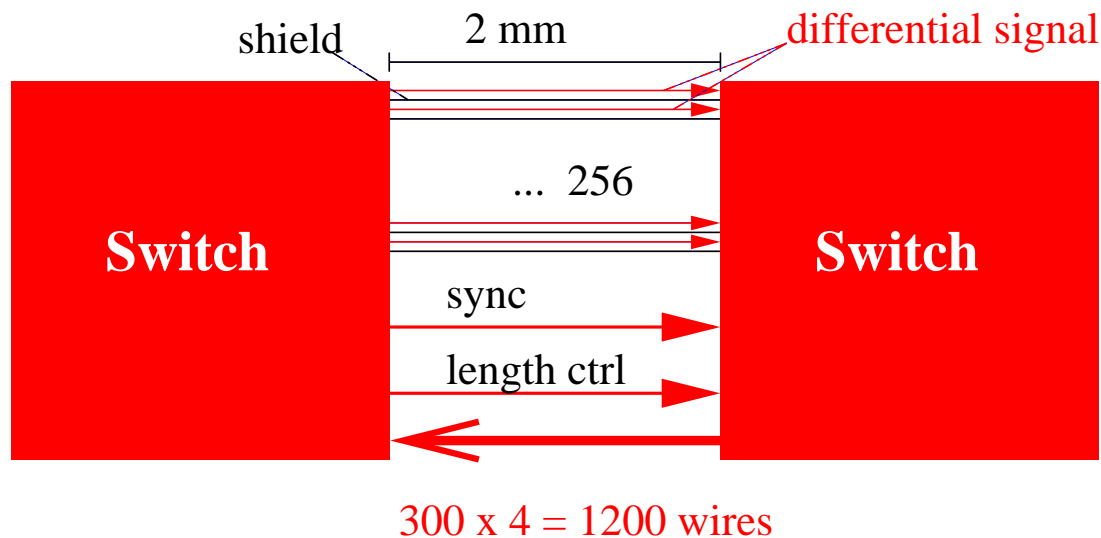

# Data Link Layer

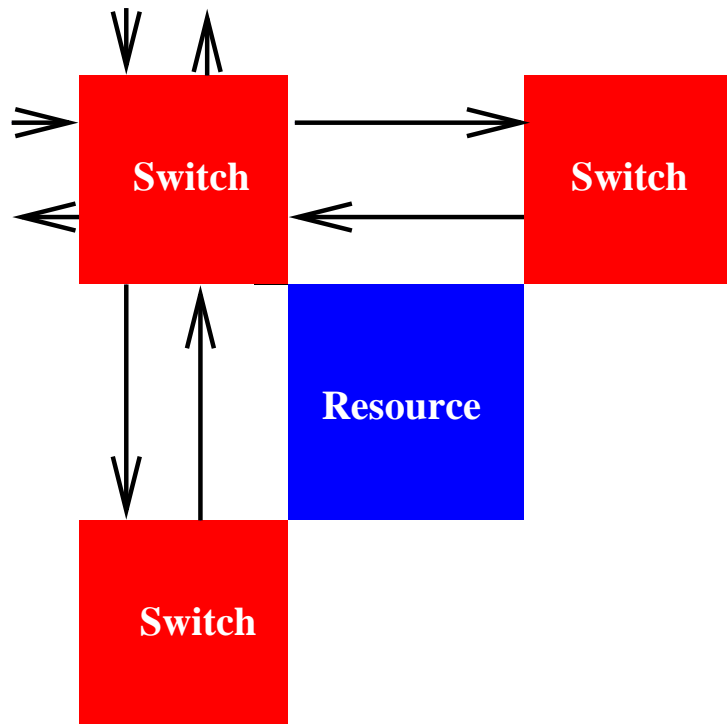

Parameters:

- Line frequency versus switch frequency
- Buffering
- Error correction
- Power optimization encoding

Nostrum status:

- Physical packet = data link packet
- Physical clock = data link clock
- Single packet input buffer
- Error correction
- On/off activity control

# Network Layer

Parameters:

- Link layer cell size vs. network layer packet size
- Network address scheme
- Routing algorithm
- Priority classes
- Error correction

Nostrum status:

- Link layer packet = network layer packet
- Relative x-y addresses
- Deflective routing with no buffers and no routing tables
- Virtual circuits with guaranteed bandwidth and delays
- No error protection

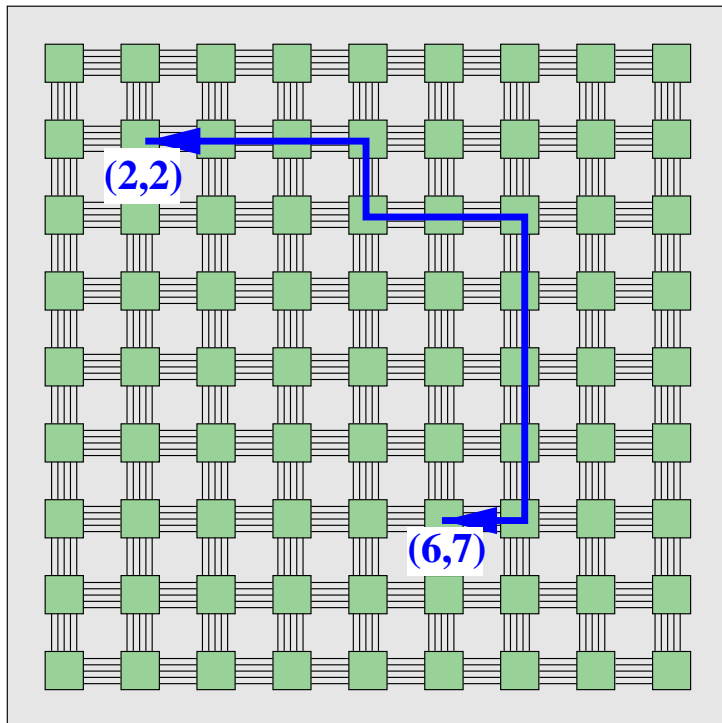

# Session Layer

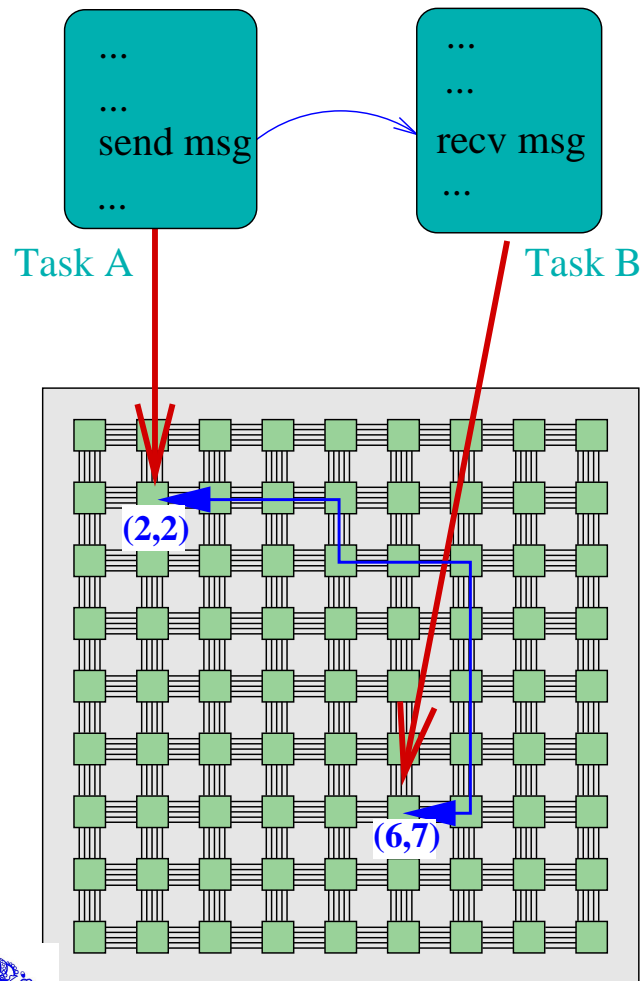

Parameters:

- Task level communication primitives
- Message passing
- Shared memory based communication
- Synchronization
- Error correction

Nostrum status:

- Set of communication primitives defined
- Both message passing and shared memory
- User controlled synchronization
- Optional end-to-end data protection

## Session Layer Communication

- Message passing communication:
  - ★ open/listen/accept/bind primitives to open a channel
  - ★ send/receive to communicate
  - ★ close to tear down the channel
  - ★ blocking/non-blocking send/receive
- Shared memory communication:
  - ★ allocation
  - ★ read/write
  - ★ free
  - ★ interruptable/non-interruptable
- VHDL,C and SystemC libraries under development



# Application Layers

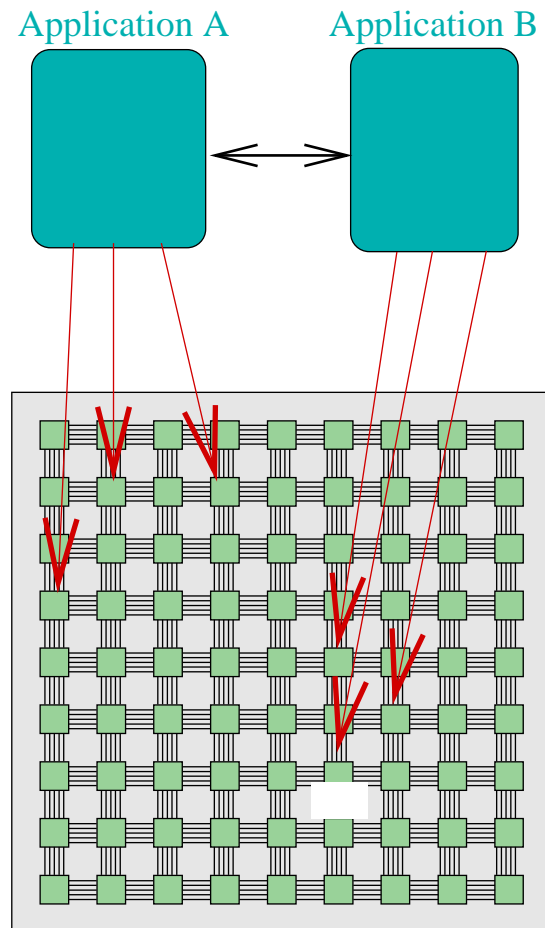

Application specific communication services;  
E.g. the NoC operating system could use:

- Task/resource database access protocol
- Task migration protocol

# Overview

Introduction

Topology and Structure

Protocol Stack

**The Network Layer and the Switch**

Data Protection



# The Network Layer

- Packet switched best effort service
  - ★ Packets are guaranteed to arrive
  - ★ Packet payload may be protected (4 levels of protection)
  - ★ Load dependable delay in the network
  - ★ Load dependable delay at the network access point
- Virtual circuit service
  - ★ Guaranteed bandwidth
  - ★ Guaranteed maximum delay
  - ★ Multicast circuits
  - ★ Based on packet switching service



# The Bufferless Switch

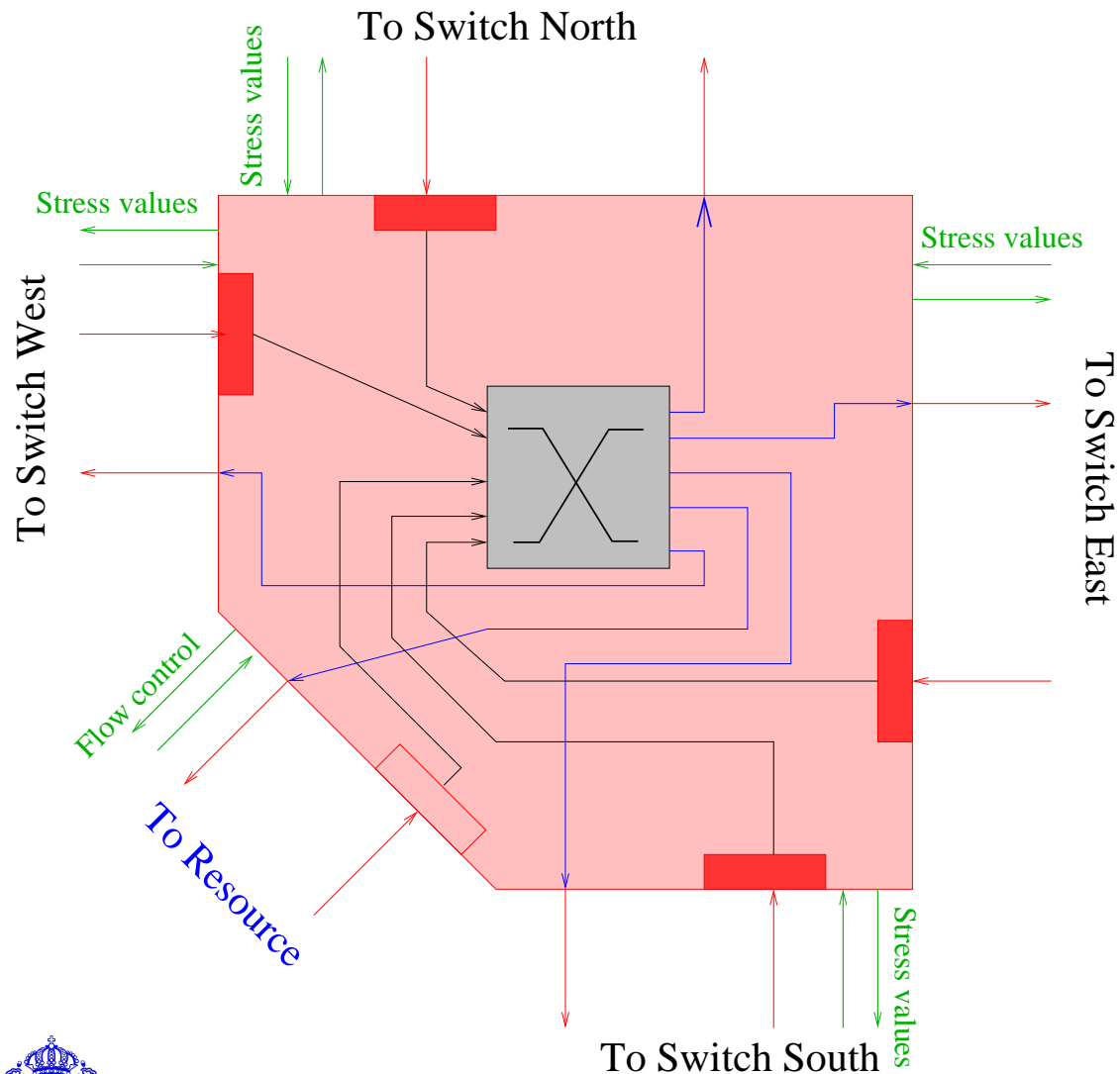

- + No buffers
- + No routing table
- + Small area
- + Short delay
- + Low power consumption
- Non-shortest path
- Header overhead due to destination address

# Stress Value Effect on Buffer Sizes and Delays

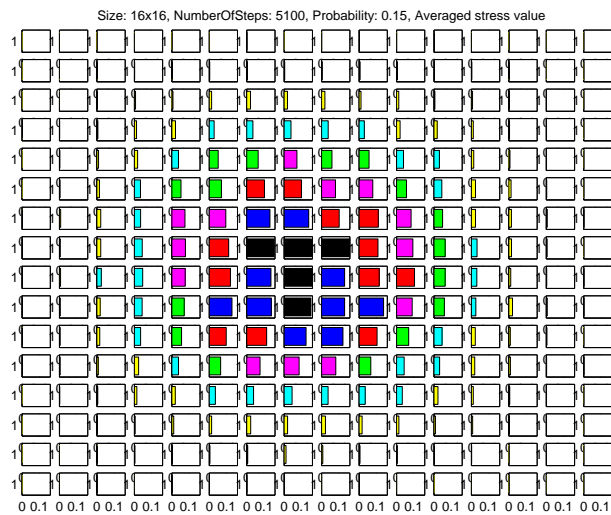

Largest average buffer size: 3.2

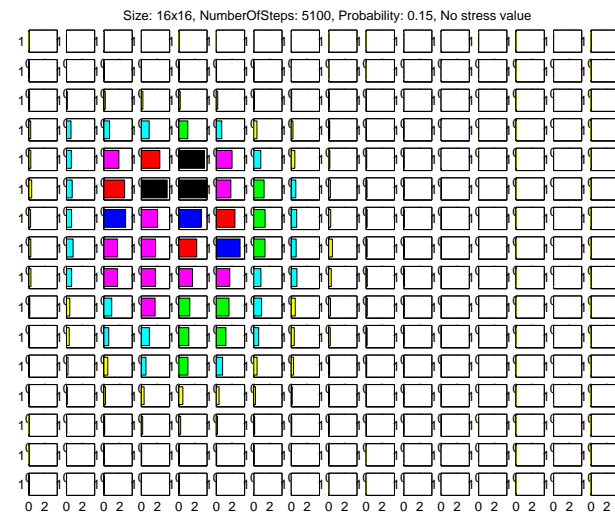

Largest average buffer size: 0.1



# Stress Value Effect on Maximum Load

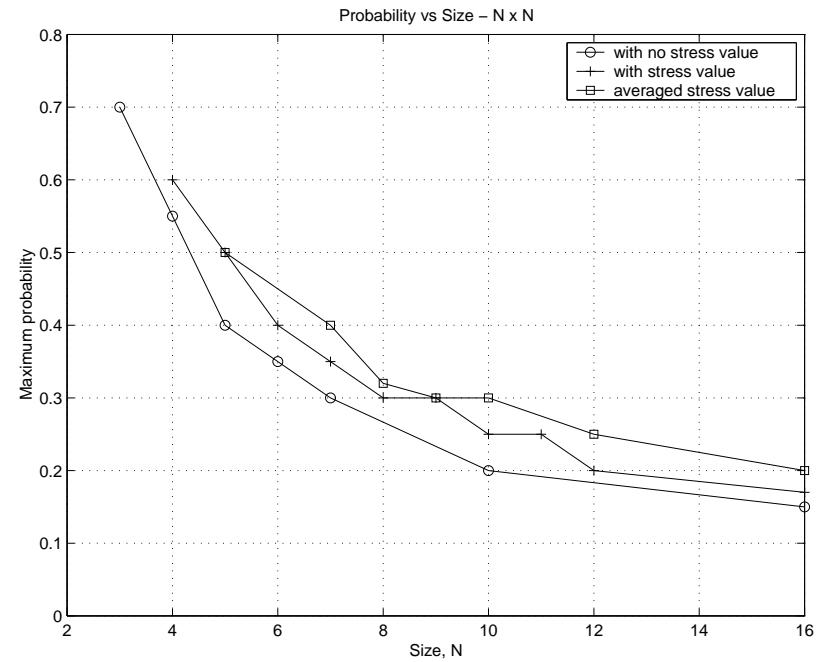

## Looped Container based Virtual Circuit

- A container packet loops between two or more end points
- The looping container establish a closed virtual circuit
- The virtual circuit allows multicast and bus protocol emulation
- Possible bandwidth allocation:

$$2^{j-d}B$$

where  $B$  = link bandwidth,  $d$  = length of the container loop,  $1 \leq j \leq d$

- Examples:

$d = 2$ : possible allocations: 100% and 50%

$d = 4$ : possible allocations: 100%, 50%, 25%, 12.5%



# Best Effort and Guaranteed Bandwidth Traffic

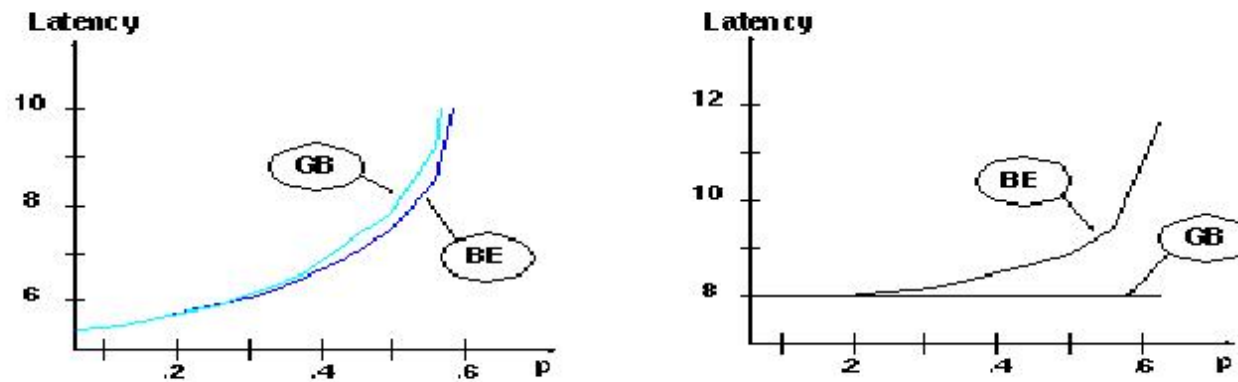

The background traffic and the AB traffic

# Overview

Introduction

Topology and Structure

Protocol Stack The Network Layer and the Switch

The Network Layer and the Switch

**Data Protection**



## Data Protection

- Two level protection: Link layer and session layer
- Data link layer protection:
  - ★ SEC-DED header protection (16/26 bits)
  - ★ Four levels of payload protection:
    - \* Maximum bandwidth - no protection (102/102 bits)
    - \* Guaranteed integrity - DED protection (90/102 bits)
    - \* Minimum latency - SEC protection (90/102 bits)
    - \* High reliability - SEC-DED protection (81/102 bits)
- Session layer:
  - ★ Normal mode: Send-and-Forget (SaF) service
  - ★ Reliability mode: Acknowledgement-and-Retransmit (AaR) service
    - \* window size  $N$ ,  $1 \leq N \leq 64$
    - \*  $2N$  packets are buffered in sender and receiver
    - \* End-to-end flow control mechanism
- in total 8 modes available



## Summary of Nostrum Status

- Nostrum defines a 2 D mesh topology;
- Protocol stack for link layer, network layer and session layer;
- Packet switched and virtual circuit communication services;
- Buffer-less, loss-less switch with no routing tables;
- 2 level data protection scheme;
- Session layer communication primitives;
- Flexible NoC Simulator;

Further information: [www.imit.kth.se/info/FOFU/NOC/](http://www.imit.kth.se/info/FOFU/NOC/)

