

Wireless Internet Access. “From the Peruvian Amazonia to the Swedish Silicon Valley”

Alberto Escudero Pascual *alberto@it.kth.se*
Royal Institute of Technology - KTH / IMIT
Electrum 204 - S 164 40 Kista
SWEDEN

1 Nov 2000

Abstract

In the following paper we present two initiatives that want to provide Internet Access making use of wireless technologies. The first one, FlyingLinux.NET, provides broadband wireless access for the students of the new IT University programme in the so called Swedish Silicon Valley in Kista (Stockholm) using TCP/IP over IEEE 802.11b protocol. A second initiative, EHAS¹, is using low cost technologies to provide e-mail access to isolated medical personnel in the Peruvian Amazonia using TCP/IP over AX.25 protocol.

Both projects try to give an answer to two very different realities with very specific needs. Today it is possible to send an e-mail from a health establishment of Shucushyacu in the Amazonia to the restaurant of the Royal Institute of Technology in Kista. It is up to us what is in the “body” of the message.

FlyingLinux.NET

IEEE 802.11b wireless environment supporting “link” and “IP” level mobility.

Summary

The wireless distribution FlyingLinux [3] started in October 1999 in the Telecommunication Systems Lab at Teleinformatics KTH with the objective of studying the possibility of using *MobileIPv4* and

¹EHAS stands for Enlace Hispanamericano de Salud. Hispano-American Health Link <http://www.ahas.org>

standard *DHCP-based* wireless access for student labs. The result of that work was the FlyingLinux environment available for one hundred students and teachers during the 2G1303 project course that was held from March to May year 2000.

The first Flying Linux infrastructure used Bambi² as the core linux distribution. Bambi-6.1 included native support for WaveLAN/IEEE 802.11 PCMCIA cards, Andrew Filesystem and Kerberos.

As one of the results of the project course The FlyingLinux.NET developing team kept working on a new Linux distribution now called FlyingLinux.NET - THE WIRELESS DISTRIBUTION - focusing on security in wireless environments and mobility.

FlyingLinux is also the first linux distribution aimed at mobility services. We have taken care of the security issues including Kerberos support and OpenSSH. FlyingLinux is part of the Open Source movement. We have included software that has been developed at KTH under the GPL³ licence.

Description

The “FlyingLinux.NET” environment was conceived to offer internet access for the students and researchers of the new IT-University study programme. Each student or researcher uses a 802.11b compliant pcmcia card to get wireless connectivity using a set of access points available in three

²Bambi is linux distribution developed at KTH that includes support for the Kerberos and AFS environment.

³More information about the GPL licence is available at: <http://www.gnu.org>

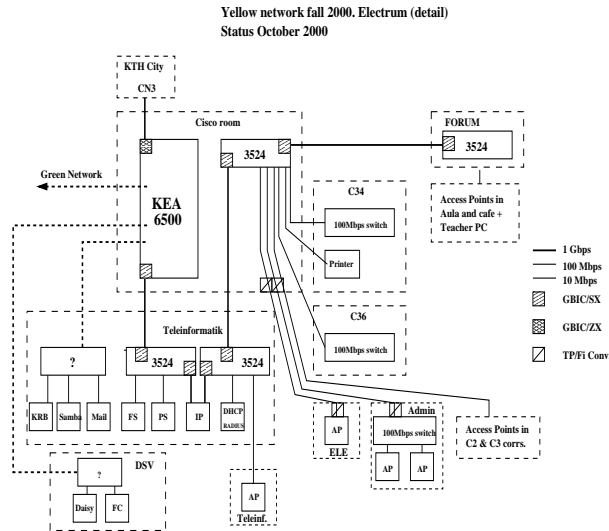

Figure 1: Yellow network topology at IT-University

different buildings and common areas. Mobility is supported between the radio cells using “link level” handover or MobileIP when roaming between IP networks. FlyingLinux environment allows students to attend lectures with their laptops, take notes and see online documentation while they receive mail.

FlyingLinux.NET is proud of being probably the biggest wireless academic network in the world. One of our main objectives when building the network is to understand how the new wireless technologies can be integrated in everyday life and to be able to study in a real scenario its possible benefits.

Network Topology

The IT-University network is divided in three functional networks called (Red, Yellow and Green). The *Red* network hosts the computer infrastructure of the administration and economical departments. The *Yellow* [Fig. 1] network is a C subnet in which each student and teacher has an allocated IP address. The *Green* network is a WAN composed of a set of different IP subnets in which IP mobility is supported thanks to *Mobile IPv4* protocol [1].

In the *Yellow* network, mobility is supported in the “link level” thanks to a set of access points that cover: Electrum building, IBM Forum lecture halls and Glassvägen (a common area with restaurants, library and meeting rooms). New security measures

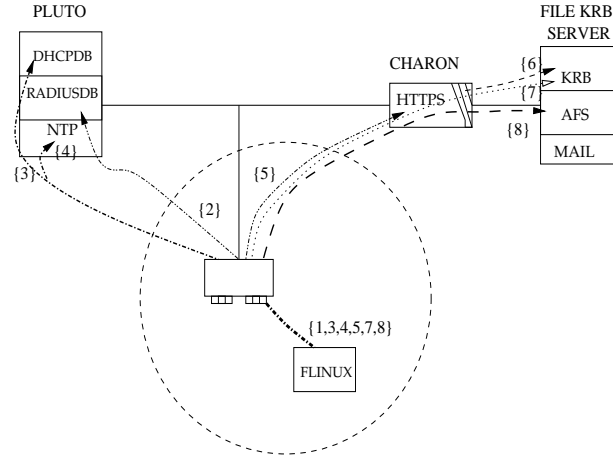

Figure 2: Authentication and wireless access in the IT-University Yellow network. Providing security in 802.11b.

[Fig. 2] has been introduced in the network to allow only authorized personnel to get wireless connectivity. In the *Green* network, wireless access is available through a set of *MobileIP Foreign Agents* that provide “*IP level*” mobility. The *Mobile IP* method supports transparency above the IP layer, including the maintenance of active TCP connections and UDP port bindings. The Foreign Agents allows “roaming” in other networks by providing the necessary means for the mobile nodes to keep the same IP address (Home IP network). The Authorization mechanisms to get access to the *Green* network rely on the ones provided by *MobileIPv4*.⁴

Hispano-American Health Link

Communication for Isolated Doctors in the Countryside of Latin America.

Summary

The “Hispano-American Health Link”[4]project (“Enlace Hispano-Americano de Salud”, EHAS) was conceived to offer communication infrastructure and access to medical information for the rural healthcare faculties that work where conventional

⁴The default authentication algorithm uses keyed-MD5 in “prefix+suffix” mode to compute a 128-bit “message digest” of the registration message.

telephony has not arrived. The low cost and appropriated technologies employed allow access to the Internet through radio links. The offered services are based on electronic mail. It allows messages as well as documentation interchange between colleagues, remote training and access to medical databases. Some of the services are managed by the so-called "information access facilitators" which are specialists in this field.

Description

The partners of the project are The Bioengineering & Telemedicine Group (GBT), the Spanish National School of Health (Carlos III Institute), and the NGO Engineering Without Frontiers (ISF). We began researching in order to design the low cost communication systems and the information services adapted to the necessities of rural health-care faculties in developing countries. The EHAS project emerges like an integral initiative both to transfer technological knowledge and to provide medical information access methodologies to our partners in each of the Latin American countries. The EHAS National Nodes will be offering specific services to cover the needs within each country.

Network topology

Two of the main ideas of EHAS are low cost technology and integration with Internet resources. The employed technology is based on the radio amateur experience. EHAS network has three types of nodes in each country.

Terminal Node:

Isolated health establishments where end users are. There will be a digital link via radio with the Local Node. The user employs conventional electronic mail programs for Windows9x. A driver is used to encapsulate TCP/IP on AX.25[2] (link layer protocol for radio links). The hardware needed is a personal computer, a TNC (radio modem) and a radio transceiver.

Local Node

Several Terminal Nodes depend on it. It is where communications among Terminal Nodes are managed free of charge. The Local Node will be in

a Centre of Health, connected periodically to the Central Node by telephone. The server is a Linux box that works as a gateway between the radio network and the Central Node.

Central Node

It manages communications among Local Nodes and among Terminal Nodes depending on different Local Nodes. It is also the gateway to the Internet. The system is a Linux server where users' accounts are stored.

The experience in Peru

The first experience is being developed in Peru. The local partners are the Cayetano Heredia University (in the medical field) and the Department of Electricity and Electronics (Catholic University of Peru, in the technological domain). The National Node will be located in the Cayetano Heredia University library. Users send information requests by e-mail to the National Node where "information access facilitators" look for the information (in local or remote databases like Lilacs, Medline, etc.) that is send back to users. There will be specialists to answer specific queries from rural faculties. Distance training will be also offered coordinated with the Peruvian Ministry of Health (MINSA). The content of the courses and the subjects of the electronic conferences will respond to the specific necessities of the rural sector (based on the GBT- MINSA study carried out on Sept.-Dec. 1997)

*By: Bioengineering & Telemedicine Group and Engineering without frontiers.*⁵

Wireless bits in the mailboxes

Today, it is possible to send an e-mail from the restaurant at the new IT-University in Kista, Sweden to an isolated health establishment in Parinari in the Peruvian Amazonia. This is the way that these bits need to travel:

⁵A. Martinez; V. Villarroel; A. Escudero; F. del Pozo; M. T. Arredondo E.T.S.I.T./U.P.M. Madrid. Spain. <ehas@gbt.tfo.upm.es> <http://www.ehas.org>

1. A flyinglinux node⁶ user at the restaurant of the IT University (laptop) attaches a 802.11b pcmcia to its laptop and gets and IP address from the “Yellow” network
2. The flyinglinux node gets authentication to the network after providing the firewall with user and password information that is checked against the IT.KTH.SE Kerberos Server realm.
3. The flyinglinux node opens a mail client and sends an e-mail to a doctor in Parinari (a health establishment that depends on the Shucushyacu local node) using the IEEE 802.11b radio link.
4. The mail travels from Kista to Stockholm city and then through Sunet (Educational Network of Sweden), Nordu, Teleglobe (NY), Sprintlink (NY), Gblx(NY), Telefonica Data (NY), Telefonica Data(Peru), Unired (Educational Network of Peru), PUCP (Catholic University of Peru)
5. The mail arrives to `central.ehas.org` mail server hosted at the PUCP.
6. Some minutes later the Shucushyacu local node makes a dial-up connection and retrieves all the mail for the terminal nodes that relate on him including the mail for the doctor in the health establishment of Parinari.
7. When the doctor of the health establishment of Parinari (terminal node) checks his e-mail, a POP3 session is established with Shucushyacu (local node) and the mail is retrieved through the *AX.25* radio link.
8. It is up to them how they fill the “body” of their messages.

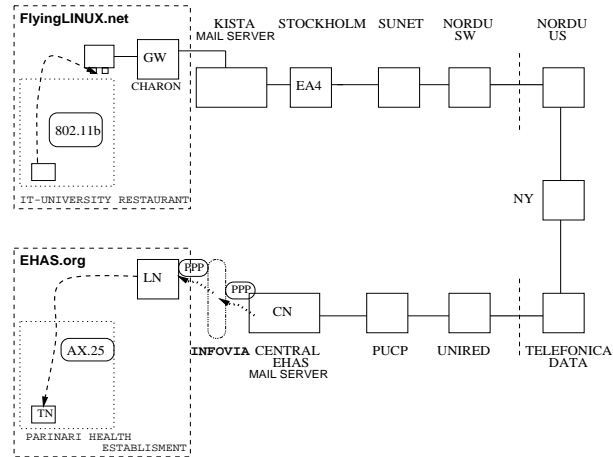

Figure 3: Wireless bits from the the restaurant at the new IT-University in Kista (Sweden) reaching an isolated health establishment in Parinari in the Peruvian Amazonia.

References

- [1] MobileIP IETF charter. RFC 2002 MobileIPv4 protocol draft <http://www.ietf.org/html.charters/mobileip-charter.html>

⁶we named “flyinglinux node” to the students or teachers laptops that have a fixed IP in the “Yellow” network.

- [2] AX.25 v2.2 protocol specification. November 1997 <http://www.tapr.org/tapr/html/ax25.html>
- [3] FlyingLinux.NET The first linux distribution supporting wireless mobility <http://www.flyinglinux.net>
- [4] EHAS. Enlace Hispano Americano de Salud <http://www.ehas.org>
- [5] Martínez A., Villarroel V., Escudero A., Del Pozo, F., "Necesidades de comunicación y acceso a información médica del personal sanitario rural del Perú". Documento interno GBT, Madrid 1997.
- [6] WaveLAN 802.11b <http://www.wavelan.com>
- [7] Wireless LAN resources for Linux http://www.hpl.hp.com/personal/Jean_Tourrilhes/Linux/Wireless.html
- [8] Hamradio tools for Linux. <http://radio.linux.org.au>
- [9] Escudero A., Martínez A., Villarroel V., Linux Dialup Gateway AX.25. Digax.25 HOWTO <http://www.flyinglinux.net/ax25>